

AT800 Specification

Basic specification

Unit dimensions: Length: 200 CM (78.74 in)
 Width: 89 CM (35.04 in)
 Height: 135 CM (53.15 in)

Unit weight: 123.5 KG (272.3 lb)

Maximum weight carrying capacity: 150 KG (330.7 lb)

Belt size: 51 x 150 CM (20 x 60 in)

Motor: 2.5 HP

Voltage: 110V 220V , 50/60Hz

Speed: 0.8~20 (KM/HR)

Incline: 10 %

Basic equipment

Hand held heart rate monitor: YES

Wireless receiving device: 5 kHz, Bluetooth and ANT+

Fan: YES

Audio: Bluetooth audio device/High quality audio

Exercise programs

P0	MANUAL
P1	INTERVAL 1-1
P2	INTERVAL 1-2
P3	INTERVAL 1-3
P4	WEIGHT LOSS
P5	HILL CLIMB
P6	CROSS COUNTRY
P7	DISTANCE GOAL
P8	STEP GOAL
H1	BASIC HRC 60%
H2	BASIC HRC 80%
U1	USER 1
U2	USER 2

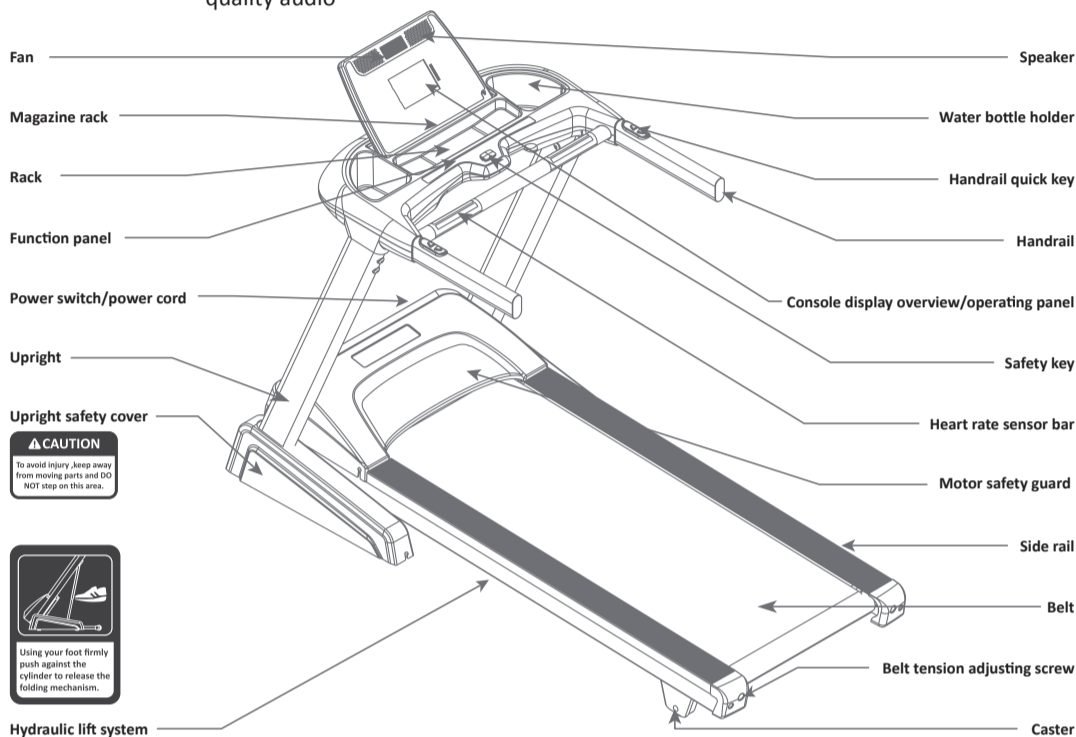

Routine Maintenance

Keep the treadmill and surroundings clean can effectively decrease maintenance issues. We recommend users to abide by following preventive maintenance procedure. Please make sure the power of treadmill is off and the power cord is unplugged for any maintenance.

Daily maintenance

- 1) Please wipe the treadmill, motor safety guard, console and display console set with clean cloth. DO NOT use any detergent.
- 2) Check if the power cord is damaged. Please contact the distributor or Alatech customer service for any damage.
- 3) Make sure the power cord is not pressed by the machine or jammed anywhere.
- 4) Check if there is any stain that can affect operation on the belt.
- 5) Check belt tension. Make sure the uncalibrated belt will not damage other components.

Weekly maintenance

- 1) Upright the treadmill and check if the pin of hydraulic lift can be securely locked.
- 2) Move the machine and clean the dust and stain underneath the treadmill. Move the machine back after cleaning.

Monthly maintenance

- 1) Make sure all screws are securely locked.
- 2) Upright the treadmill and check if there is any loose or missing component.

Yearly maintenance

- 1) Please lubricate the pin of hydraulic lift, the shaft of iron pieces, deck and belt every year to ensure normal operation.

CAUTION
 Please make sure the power of treadmill is off and the power cord is unplugged for any maintenance. Please contact the distributor or Alatech customer service for any maintenance issue.

Grounding Instruction

Grounding

The power socket of this product contains a grounding conductor. This socket must be inserted into the outlet via the power cord with grounding latch. The plug must be plugged into an appropriate outlet that is properly installed and grounded in accordance with local codes and ordinances.

Outlet

This product uses a rated voltage of 220V or 110V and comes with a three-pin power cord as shown in the following illustration. If the grounding outlet is not available, please use grounding adapter to connect this plug to the two-pin outlet. Please have qualified electrician install the grounding outlet correctly before using the adapter. Please connect the grip or similar adapter extension to the ground and fix with the metal screw whenever the adapter is used. Refer to the following illustration. Do determine the power cord is electrically related for 220V or 110V by checking the specification label or specification. Please make sure the cord is connected to the plug with correct voltage. DO not use the power cord via adapter or extension cord to avoid of any component damage or personnel injury caused by sudden voltage changes such as voltage surges and spikes.

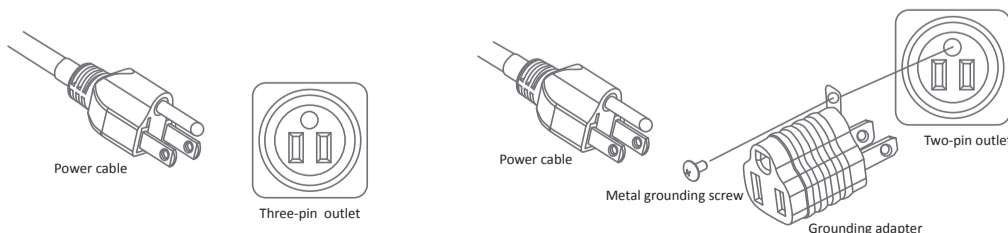

CAUTION
 • The above illustrations only show three-pin power cord power cord and outlet or two-pin outlet and grounding adapter. The type of three-prong, two-prong and grounding adapter may vary in different countries. The enclosed power cord will be provided according to local regulations of each country.
 • Make sure the power cord is connected to the outlet with correct voltage. DO NOT connect the power cord to the outlet via voltage adapter or extension cord to avoid accidental current that may damage component and lead to personnel injury.

Before Assembly

Enclosed tools

- Hex wrench
- Phillips screwdriver

Assembly parts

- Console x 1
- Display Console x 1
- Upright x 2(L & R)
- Upright safety cover x 2(L & R)

Accessory pack

- Hardware parts box x 1
- Safety key x 1
- Power cable x 1
- Line-level audio adapter x 1
- Silicon oil x 1

CAUTION
 Please contact the distributor or the Warranty card for technical support if any part is missing or you have any question.

Notices and safety tips

- 1) Please move and transport the treadmill carefully. Put the box on a level surface. Only open the box with its surface on top. It is recommended to put a protective mat on the floor.
- 2) Unpack and assemble the treadmill at the planned location to avoid unnecessary transportation. Pay great attention when unfastening cable tie that used for packing or fixing to avoid accidental bounce.
- 3) Please follow assembly procedure to assemble the treadmill after unfastening cable tie. Please fold the machine to upright and make sure the pin of hydraulic lift is securely locked if you need to lift or move it. DO NOT try to crane the machine.
- 4) DO NOT try to lift or move the machine with a single part or stand. (Refer to "Move/transport the treadmill" on P.14 for information related to moving the product.)

CAUTION
 • When assembling, make sure all nuts, screws and parts are positioned and lightly locked before proceeding to the next step. After the assembly is completed, make sure all screws are securely locked. DO NOT arbitrarily decrease the quantity of assembling screw.
 • Several parts are lubricated before delivery to facilitate assembly. DO NOT arbitrarily wipe off the lubricant. You can use lubricant to assemble parts when facing any difficulty. It is recommended to use the lithium base grease for bike.
 • Several parts are very heavy; DO NOT try to assemble the machine on your own. These heavy parts may fall and lead to personal injury. Strongly recommend to have more than 2 persons for assembly.

CAUTION
 • Please follow assembly instructions to lift or move the treadmill. DO NOT arbitrarily lift or take out the product from the package.
 • Fail to following above instructions may lead to personal injury and machine damage. Please pay great attention to these instructions.

Step 1 of Assembly Procedure

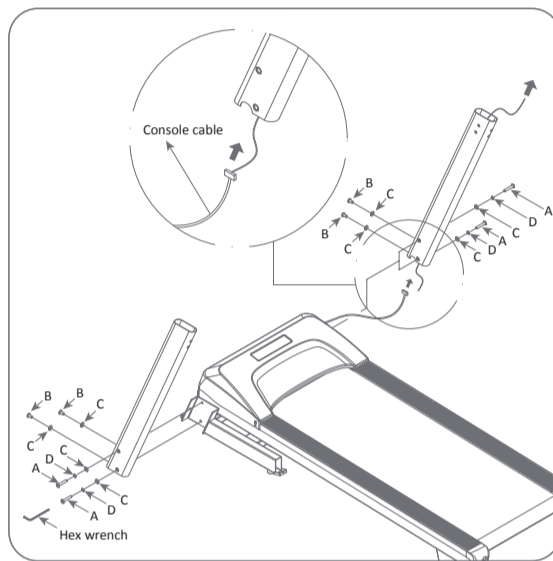

CAUTION
 • Put the console strut on the frame with great care to avoid any damage to the console cable.
 • DO NOT lock the screw tightly before you finish step 3.

Hardware pack for step 1				
Parts	Illustration	Type	Description	Qty
A		Screw	Button Head Socket Bolt (55L)	4
B		Screw	Button Head Socket Bolt (20L)	4
C		Washer	Flat washer (Ø23)	8
D		Washer	Split washer (Ø18)	4

- 1) Open hardware pack 1.
- 2) Connect the lead wire to the console cable, pull them through the right upright of the console, pull out the lead wire from the right upright and then fix the console cable to the top of upright. Please remove the lead wire then.
- 3) Put the right upright on the frame.
- 4) Use part A, C & D (2 of each) and connect the upright to the frame. Make sure all screws and washers are well positioned and lock them lightly.
- 5) Use part B & C (2 of each) and connect the upright to the frame. Make sure part B & C are well positioned and lightly locked. Confirm all screws and washers on the right side are positioned.
- 6) Repeat step 3~5 to complete the assembly of the left upright.

Step 2 of Assembly Procedure

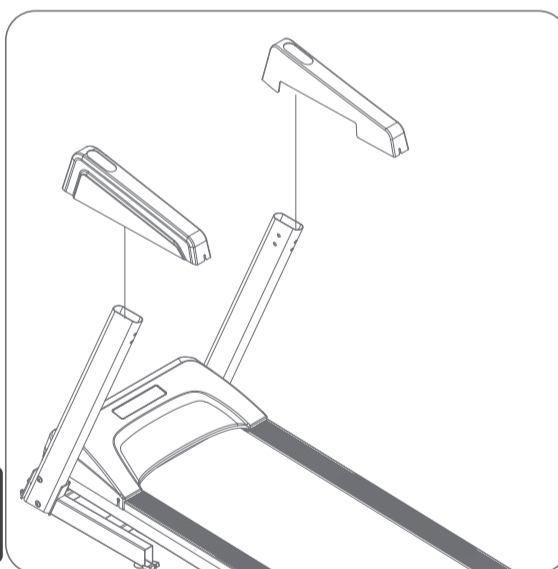

- 1) Take the left and right upright safety covers.
- 2) Put the protective cover through the right upright safety cover carefully.
- 3) Put the protective cover through the left upright safety cover carefully.

Step 3 of Assembly Procedure

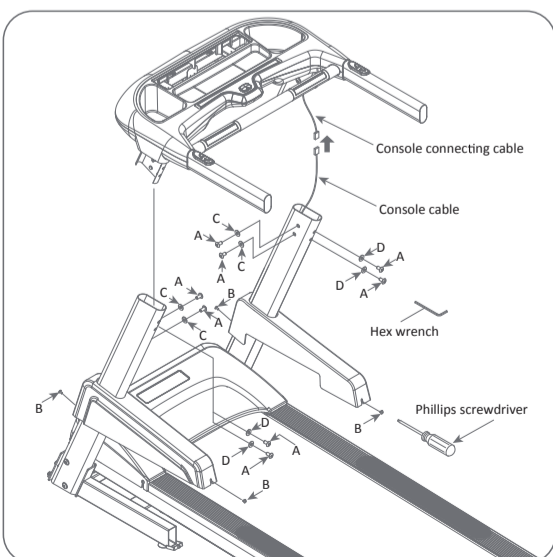

Hardware pack for step 3				
Parts	Illustration	Type	Description	Qty
A		Screw	Button Head Socket Bolt (20L)	8
B		Screw	Truss head Phillips screw (10L)	4
C		Washer	Flat washer (Ø23)	4
D		Washer	Curved washer (Ø23)	4

- 1) Open hardware pack 3.
- 2) Connect the console cable to the connecting cable on the console.
- 3) Put the console on the uprights carefully.
- 4) Use part A & C (2 of each for left and right side), connect the upright to the frame. Make sure all screws and washers are well positioned and lock them lightly.
- 5) Use part A & D (2 of each for left and right side), connect the upright to the frame. Make sure all screws and washers are well positioned and lock them lightly.
- 6) Lift the uprights safety cover of the upright on both sides and lock all screws at the lower side of upright tightly.
- 7) Use part B (2pcs for left and right side) and lock the uprights safety cover of the upright safety cover on both sides tightly.
- 8) Lock all screws tightly.

CAUTION
 • Please assemble the display console with great care. Make sure no wire is pressed or bent to avoid any damage.
 • Make sure all screws are well positioned and lightly locked. DO NOT lock the screw tightly when positioning to ensure a smooth assembly.

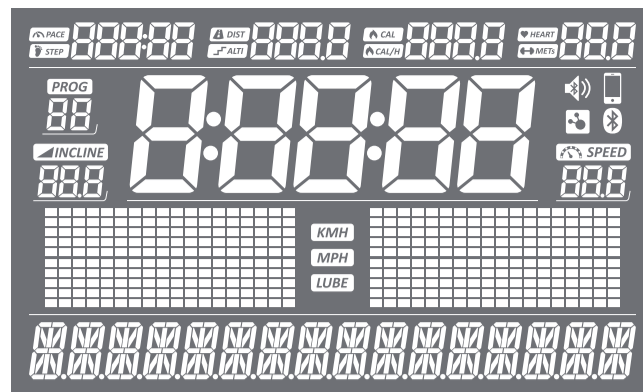
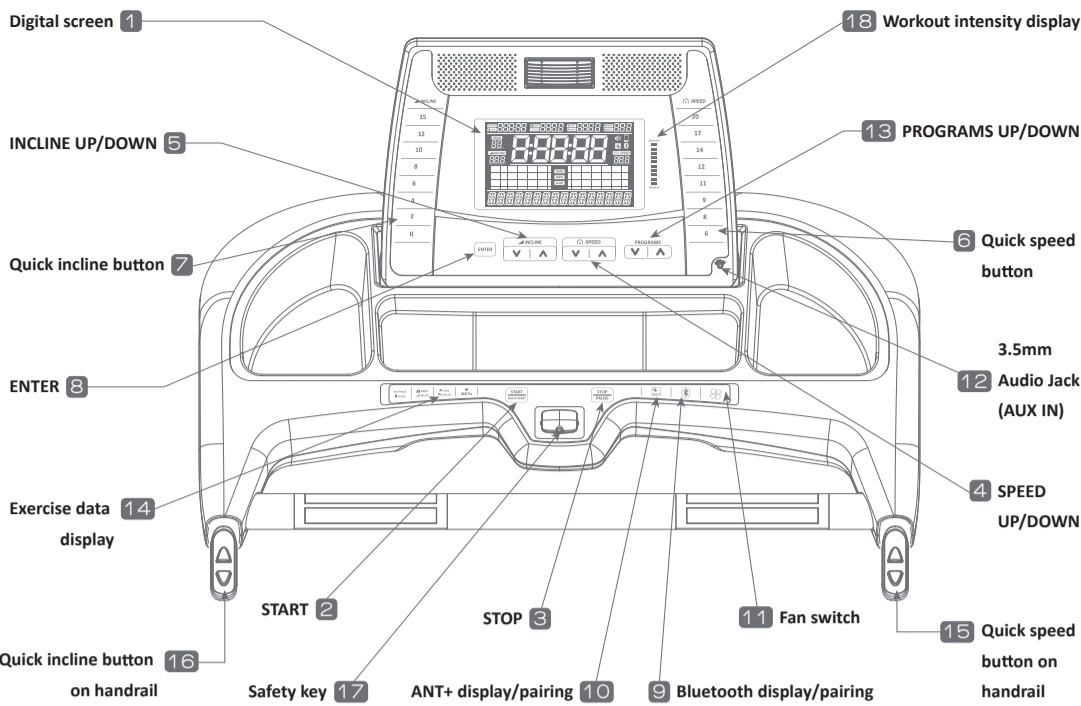

- 1** Time : display in the format of HH: MM: SS. Display your workout time or continuous workout time.
- 2** Slope : display in level. Display the slope when you are doing a fast walk or running on the treadmill.
- 3** Speed : display in km or mile. Display the slope when you are doing a fast walk or running on the treadmill.
- 4** Program : display the program selection. when you select the desired program, the program name will be showed on the screen accordingly.
- 5** KM & Mile : display the distance in digital clock in km or mile.
- 6** Reminds you to apply silicon oil: "LUBE" will be displayed flickering on the digital screen either the accumulated hours reach 100 hours or accumulated distances reach 1000km
- 7** Pace & Step : can switch the display of your current Pace, steps(Step1), step frequency(Step2), and current length(Step3).
- 8** Distance & Slope : can switch the display of total distance or accumulated slope of your workout.
- 9** Total calories & Calories per hour : can switch the display current total calories burned or calories burned per hour.
- 10** Heart beat & Workout metabolic rate : can switch the display of current heartbeat or convert the heart rate into metabolic rate to show workout intensity.
- 11** Bluetooth connection : when this indicator is on, the heart beat is the value detected by Bluetooth on the connected wearable device.
- 12** ANT+ connection : when this indicator is on, the heart beat is the value detected by ANT+ on the connected wearable device.
- 13** Smart device connection : when this indicator is on, it means the smart device is connected to the treadmill via Bluetooth.
- 14** Bluetooth Speaker connection : when this indicator is on, it means the Speaker is connected to the treadmill via Bluetooth.

Operation Panel

Please remove the transparent protective film on the operating panel before use.

- 1) Digital screen:** displays information such as the workout time, distance, calorie, heart rate, step, slope and speed.
- 2) START:** press this button to start your workout, or start the exercise after selecting the program. Press to restart the exercise after the pause.
- 3) STOP:** press this button to pause and press it again to stop the exercise and collect the data. Press this button to return to the previous program when setting program value.
- 4) SPEED UP/DOWN:** adjust the speed (unit=0.1, ranged from 0.8~20KM). It can also help you to enter quickly when setting program value.
- 5) INCLINE UP/DOWN:** gradually increase or decrease the slope (level unit=1, total=10%). It can also help you to enter quickly when setting program value.
- 6) Quick speed button:** quickly switch different speed values including warm-up and fast run.
- 7) Quick incline button:** quickly switch different slope angles including warm-up and workout.
- 8) ENTER:** press this button to proceed to the input of next data when setting program value.
- 9) Bluetooth display/pairing:** click this button can switch the heart rate of paired device. Long press this button to pair any wearable device.
- 10) ANT+ display/pairing:** click this button can switch the heart rate of paired device. Long press this button to pair any wearable device.
- 11) Fan switch:** turn on/off the fan.
- 12) Audio Jack (AUX IN):** connect your media player to the treadmill via the enclosed 3.5mm Audio Jack (AUX IN).
- 13) PROGRAMS UP/DOWN:** select the program ; there are 13 programs available.
- 14) Exercise data display:** exercise data switch; there are 4 types of data available, including Pace/steps(Step1)/step frequency(Step2)/current length(Step3), distance/slope, total calorie/calorie per hour and heart rate/training intensity.
- 15) Quick speed button on handrail:** located on the right handrail; increase or decrease the speed (unit=0.1KM, ranged from 0.8~20KM).
- 16) Quick incline button on handrail:** located on the left handrail; gradually increase or decrease the slope (level unit=1, total=10%).
- 17) Safety key:** you can turn on and operate the treadmill after the switch is inserted. The machine is in emergency mode when the safety key is not inserted and no operation will be allowed.
- 18) Workout intensity display:** display training intensity; determine current intensity according to the heart rate detected.

Gentle reminders

You can choose to display your workout data by pressing "PACE/STEP" button. "Pace" shows target speed in minutes per mile (or kilometer), "Step 1" shows steps, "Step 2" shows step frequency per minutes, or "Step 3" shows your current length, total 4 workout data.

Preparations before Use

The treadmill is a simple and efficient training equipment and your shortcut to pursue a healthy lifestyle.

The treadmill is an equipment for aerobic exercise that can facilitate weight loss, cardiopulmonary function enhancement, and muscle tension and basic metabolic rate improvement. Good exercise habits are helpful for achieving these goals. This product can help you to build healthy exercise habit at home.

Please evaluate your physical condition before the exercise and pay attention to following advice:

- 1) Do warm-up before you start to run. Warm-up can help stretching your muscles and avoid sports injury.
- 2) Wear sneakers with a gum sole. This can effectively relieve the pressure to knees during the workout.
- 3) Please focus on your workout and please attach the safety clip to your clothing, please also pay highly attention to your safety to use smart device or any media player to watch TV/magazine during workout as this may lead to sport injury caused by poor posture.
- 4) Gradually increase your running speed. Release your grip on the handrails at a comfortable speed.
- 5) We recommend to limit your exercise to 30~60 minutes. Excessive exercise may result in knee injury or other potential injuries.
- 6) Decrease your speed from a fast walk to a slow walk for a gradual recovery when your workout is coming to the end. DO NOT leave the deck immediately after the workout to avoid dizziness.

Treadmill location

Place the machine on a level ground. Clearance requirement: 200cm at the rear, 100cm at left and right sides and 30~50 cm at the front. DO NOT place the machine in front of the indoor/outdoor vent, in the garage, in the open yard, outdoors, or near the water supply.

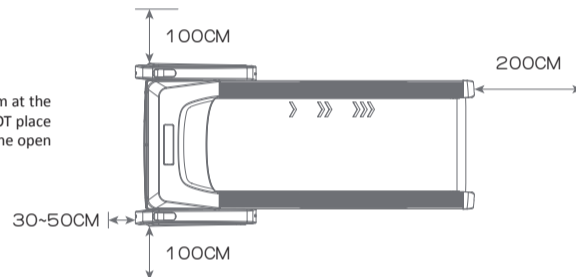

CAUTION

DO NOT start the machine with your feet on the belt. Please stand on foot rails when starting the machine. Start walking on the treadmill only when the belt starts moving. DO NOT start the machine with the fast run speed. DO NOT try to jump on the machine.

Assembly Instruction

CAUTION

Please follow the assembly instructions and steps in this manual and make sure all parts are securely fastened. Fail to follow the instructions may lead to loose parts on the treadmill. Loose parts can result noise or may cause personnel injury. Please thoroughly read the assembly instruction to avoid any damage to the treadmill.

Please always make sure that serial number on treadmill is same as warranty card indicated. If not, please do not assemble machine and contact Alatech's service center or distributor for further assistance. If maintenance needed, the serial number on machine and warranty card must be the same, if inconsistent serial number is found, we will not provide warranty.

Ensure your warranty by following notices:

- 1) The warranty will be invalid if there is no distributor stamp on warranty card or the content is incomplete. However, this warranty does not cover following conditions:
 - When customers can provide original invoice or proof of purchase
 - When the related proof of purchase can be provided by document
- 2) Please bring this warranty card when you need maintenance services.
- 3) Please contact approved distributors or service locations while your warranty is still valid.
- 4) Please keep this warranty card in a secure place.

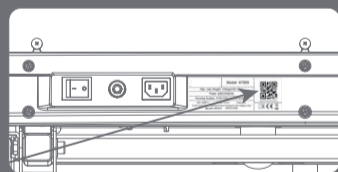

Treadmill Serial Number

Move / Transport the Treadmill

How to fold

Please hold the frame at the rear side of machine or under back roller securely and upright the deck carefully until the pin of the hydraulic lift is locked. Please put down the deck carefully and make sure it does not fall. To unlock the fixation, please hold the frame at the rear side of machine or under back roller securely and lightly kick the orange pin of hydraulic lift and press deck slightly. Put the deck on the floor carefully.

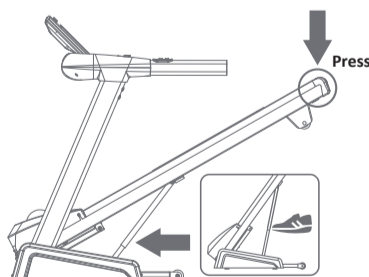

How to move

The treadmill comes with two sets of casters. Please fold the treadmill and make sure the deck is fixed before moving it. Hold the handrails tightly, make the machine lean backward and move it. Attempt to move or transport the treadmill without a folded and fixed deck can result in personnel injury or machine damage.

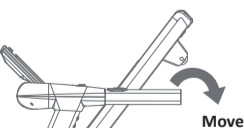

How to transport

The treadmill comes with two sets of casters. Please fold the treadmill and make sure the deck is fixed before moving it. Hold the handrails tightly, make the machine lean backward and move it. The treadmill is very heavy. DO NOT arbitrarily move it unless it's necessary.



CAUTION

- There is a safety lock on the hydraulic lift under the machine. If you like to put down the deck, please gently kick the orange pin of hydraulic lift and press deck slightly, then lower the deck carefully on the ground.
- The treadmill is very heavy. Please ask another person to move or transport it with you. Before moving or transporting, make sure the deck is folded and the pin of hydraulic lift is fixed. DO NOT try to arbitrarily move or transport the treadmill on your own. Fail to follow above instructions may lead to personnel injury and machine damage. Please pay great attention to these instructions.

Safety key

The machine will not start operating until the safety key is correctly inserted into the port. Always attach the safety key to your clothing during workout. The safety key is the device to ensure your safety, the emergency stop cutting off the power in case runner accidentally falls down on the treadmill. Please check every 2 weeks to ensure the safety key work functionally.

Correct use

Start with slow speed and gradually increase the speed to a comfortable level. DO NOT let the machine run by itself. Please pull out the safety switch, turn the power off and unplug the power cord when not in use. Please start the machine with slow speed. Stand on foot rails first and try to turn your trunk or lean forward. Please stop using any sport equipments including the treadmill immediately once you feel any dizziness, pain, exhaustion or difficult breathing.

Leveling

Level the machine before use. When the treadmill location is determined, please adjust the regulating foot pad on the deck and fix it after adjusting to the best position. Make sure the deck is adjusted to an appropriate height before use.

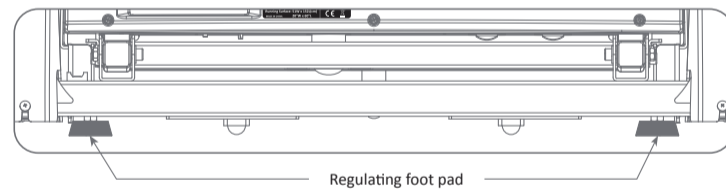

Turn on the power

Make sure the power cord of treadmill is correctly plugged. The indicator should light up when the power is on. The digital screen will light up after the beep; 3 seconds after the machine enters standby status, you can press "Quick Start" twice to proceed to fast exercise or select "PROGRAMS" and the machine will start to operate at low speed.

CAUTION

- DO NOT use the machine without using the safety clip. Please attach the safety clip to your clothing before the workout. Try to pull out the safety switch and make sure the clip does not fall from clothing.
- Damaged power cord or outlet may lead to irregular machine operation and personnel injury. Please stop the operation or workout immediately if this occurs.

Adjust / Maintain the Belt

Belt adjustment

The position of belt is adjusted before shipment. However, sometimes the belt may shift off center during transportation. To adjust a slipping belt, please use the enclosed hex wrench turn the screws at rear (both sides) of the deck to the right by 90 degrees until no slippage occurs. Make sure the belt is not moving while adjusting the screw.

The belt stays at the center

The belt slides to the left: When the belt slides to the left, please fine-tune the rear left screw in a clockwise direction to the right under high speed operation (10KM). Repeat above steps until the belt moves back to the center if the belt still shifts off after 30~60 seconds under high speed operation.

The belt slides to the right: When the belt slides to the right, please fine-tune the rear right screw in a clockwise direction to the right under high speed operation (10KM). Repeat above steps until the belt moves back to the center if the belt still shifts off after 30~60 seconds under high speed operation.

Belt maintenance

"LUBE" will be displayed on the digital screen when the accumulated hour reaches 100 hours or distance of 1000km as a reminder of belt maintenance. Please press "STOP" or remove the safety switch and maintain the belt under standby status. After finishing belt maintenance, please press "START", "SPEED UP" and "SPEED DOWN" simultaneously to clear the accumulated hours or kilometers. For belt maintenance, apply the silicon oil (the whole bottle) to the inner side of belt. After the oil is fully applied to the belt, please operate with high speed (10KM) for 10 minutes to make the oil spread evenly on the belt.



CAUTION

- DO NOT adjust the belt when the machine is operating. A tight belt may bring extra load to the frame and electronic components and therefore should be avoided.
- When the belt is adjusted to the center, please test with the speed of 10KM for 30~60 seconds to check if the belt is appropriately tightened and if any deviation occurs. Keep your fingers, hair and clothing away from the belt when testing.



Warranty card

Assembled on Y M D

Model number

Serial number

Dealer Stamp

Manufacture address: No.405 Tongxin Road, Tongxiang Economic Development Zone, Zhejiang 314500, China
TEL: +86-573-8862 8666

Please keep this warranty card.

The following precautions can guarantee your warranty rights:

- 1) If the warranty card is not stamped with the company seal (or dealer) or the contract is incomplete, it may lose the warranty rights, the following conditions are not within this limit:
 - Submit original invoice or proof of purchase
 - Distribution document that can provide relevant proof of purchase
- 2) Please show this warranty card when requiring repair service.
- 3) During the warranty period, please contact the dealer or maintenance base authorized by the company.
- 4) You are given only one original copy of this warranty card please preserved it properly.

Treadmill Precautions

Please abide by following instruction to avoid burn, fire, electric shock or injury to persons:

- Never use the treadmill before securing the safety key clip to your clothing.
- Stop exercising immediately and consult your physician before continuing, if you experience any kind of pain, including but not limited to chest pains, nausea, dizziness, or shortness of breath.
- Maintain a pace you feel comfortable during the workout. DO NOT run with extremely high speed.
- Do not wear clothes that might catch on any part of the treadmill.
- Always wear athletic shoes while using this equipment.
- At no time should more than one person be on treadmill while in operation.
- Do not jump on the treadmill or stand on plastic parts such as Motor safety guard, Upright safety covers or rear cover, to avoid any improper use or action.
- This treadmill should not be used by persons weighing more than Max. User Weight. Failure to comply instructions will void the warranty.
- Disconnect all power before maintenance, moving or folding the treadmill.
- Please use a wet cloth to clean the surface for machine maintenance. DO NOT use any detergent.
- The treadmill should never be left unattended when the power is plugged in. Always UNPLUG from outlet when NOT in use.
- DO NOT cover the machine with blanket or fabric. The blanket or fabric may cause overheat and lead to fire, electric shock or other personnel injuries.
- Make sure the machine is connected to the correct outlet. Failure to comply instruction will void the warranty.
- Please place the machine on a level ground. DO NOT place and use the machine on an uneven ground.

⚠ CAUTION

- Please turn off the power and unplug the power cord immediately after finishing the workout.
- Always turn off the power and unplug the power cord before cleaning, performing maintenance, move or taking off parts.

To Ensure Your Safety

Please abide by following instruction to avoid burn, fire, electric shock or injury to persons:

- Keep children under 13 or pets always away from the treadmill at least 3M (10ft.) at all times. Children under 13 are not allowed to use this machine.
- The use by children between 13~18, seniors over 65 or disabled people must be under the surveillance of other adults to avoid any danger.
- Please follow instructions in this manual when using the machine.
- DO NOT use parts other than manufacturer or distributor recommendation to avoid personnel injury.
- Please stop using the machine immediately and contact maintenance staff if you encounter power cord or plug damage or irregular operation caused by accidental drop, impact or soaking in the water.
- Put the power cord away from the surface with high temperature. DO NOT lift the machine with the power cord or use the power cord as a handrail.
- Make sure the vent of the machine is clean before the workout. Remove substances like cotton wadding and hair.
- DO NOT put, drop or insert any object in openings as it may result in electric shock. Alatech is not responsible for any damage rising from failure to follow instructions.
- The motor controller generate heat. DO NOT use any spray near this area as it may result in combustion.
- Turn off all equipment and power and unplug the power cord when the workout is completed or the connection is removed.
- Only use this machine in a place with controlled temperature. DO NOT use in the garage, porch, bathroom, kitchen, carport or outdoors. We is not responsible for any damage rising from failure to follow instructions.
- This treadmill is for ordinary household use ONLY. The warranty does not cover applications in business place, rental service, school or organization.
- Specific sole materials of shoes may generate static electricity. To avoid electric shock, please wear sneakers with gum sole instead of plastic or insulated one.
- Before using the machine, please DO consult your physician and evaluate by physical exam, especially for users are over age 45, users with pre-existing health problems from family history such as high pressure or heart disease, users with high cholesterol or obesity, smokers, expectant mother, and users have not done a workout regularly over one year.

⚠ CAUTION

This product is for indoor use only. Please pay attention to room temperature and humidity. If the machine is placed in the environment with unstable temperature and humidity, it is recommended to warm-up the machine to ambient temperature before the workout. Fail to follow this instruction may lead to early damage to electronic components.